

E346V+

SIMPLE AND FLEXIBLE CLAMPING SYSTEM

VACUUM-based tool-holder clamping system allows greater measurement reliability.

The vacuum, generated inside the interchangeable rotating spindle holder, allows the tool holder to be adapted to a wide range of shanks without the need to change any adaptors.

No maintenance. No wear.

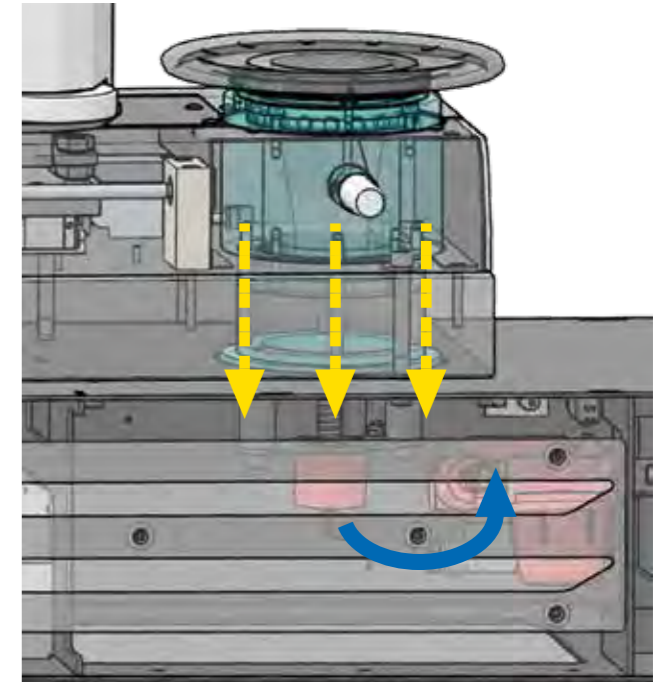

Granite is a natural material with one of the lowest thermal expansion coefficients in the world, an important peculiarity when it comes to measurement: for this reason, the E346V+ presetter machine is equipped with a **NATURAL GRANITE** base and column.

The measuring range is 360 mm in diameter and 460 mm in height. The rotating spindle holder is completely interchangeable (with a concentricity accuracy of 2 microns / m) and equipped with a mechanical rotation brake.

Repeatability is within everyone's reach. It's your choice.

INSPECTION FUNCTION

How often do you check the state of the cutting edge?

In this case, the E346V+ is able to use the INSPECTION function to quickly identify the areas of wear and tear.

What are you waiting for?



INNOVATIVE. RELIABLE. VERSATILE.